

REQUEST FOR QUOTATION (RFQ)

PR/PP No.: DRMD 2022-03-009  
End-user: DRMD-RR0S  
Name of Project:

RFQ No.: 2022-05-293  
Date: MAY 11 2022  
ABC ₱63,998.00

PURCHASE AND DELIVERY OF OTHER SUPPLIES AND SE: MACHINERY AND EQUIPMENT FOR DRMD

Mode of Procurement: SMALL VALUE PROCUREMENT

Sir/Madam:

Please quote your lowest price on the item/s described below inclusive of taxes duly signed by you or your authorized representative, subject to the Terms and Condition provided in this RFQ and submit personally to the Office of the Disaster Response Management Division, 40 North Drive, Baguio City or through email at [bacsec.car@dswd.gov.ph](mailto:bacsec.car@dswd.gov.ph) on or before MAY 17 2022, 12:00NN.

ENRIQUE H. GASCON JR.  
BAC Chairperson

**TERMS AND CONDITIONS:**

1. Quotations in excess of the ABC will be **REJECTED**.
2. For total quoted price, quotations with a **dash or zero shall be deemed free of charge**.
3. All entries must be typewritten/printed/longhand. **Any erasure in the quotation must be countersigned by the bidder/representative**, otherwise quotation will be rejected.
4. The Procuring Entity **may give due preference to goods being offered with green component**.
5. If necessary, the BAC through the TWG, may require an ocular inspection of the venue/place of business/goods being offered.
6. Delivery of Goods / Services is **as indicated** in the next page.
7. Price validity shall be for a period of **120 calendar days** from RFQ Opening of the BAC until confirmation of Purchase Order by the **winning supplier**.
8. The following documents shall be attached upon submission of quotation, otherwise your quotation will not be accepted, please disregard if already submitted:
  - a. **Updated Mayor's / Business Permit**
  - b. **PhilGEPS Registration Certificate or PhilGEPS Registration Number to be indicated in space below (except for Negotiated Procurement - Emergency Cases, Sec. 53.2, RA 9184 IRR)**
  - c. **Income/Business Tax Return (for Small Value Procurement, Direct Contracting above P500K, Emergency Cases above P500K, and Lease of Real Property/Venue).**
    - o **Official Receipt issued by BIR( a mere picture of the receipt can suffice)**
9. Where there is discrepancy between: (a) total price per item and unit price for the item as extended or multiplied by the quantity of that item, the unit price shall prevail; (b) stated total price and the actual sum of prices of component items, the lower shall prevail; (c) unit cost in the detailed estimate and unit cost in the bill of quantities, the lower shall prevail.
10. Suppliers/Contractors who **refuse to accept correction of price offer after Bid Evaluation may be disqualified**.
11. Award of Contract shall be made to the Lowest Calculated Responsive Quotation (LCRQ) that complies to the **technical specifications** and the **terms and conditions** stated herein.
12. The BAC shall require the bidder with Lowest Calculated Responsive Quotation to submit **Omnibus Sworn Statement for Sec. 53. 2 Negotiated Procurement –Emergency cases amounting to P500, 000 and above and Sec. 53.9 Negotiated Procurement- Small Value Procurement amounting to P50, 000.00 and above prior to issuance of Award /Purchase Order**.
13. If the Supplier fails to deliver the required goods /services as specified in the Award / Purchase Order, the Procuring Entity may **disqualify bidder from participating future procurement activities to be conducted by DSWD-CAR**.
14. **Liquidated damages equivalent to one tenth of one percent (0.001)** of the value of the goods not delivered within the prescribed delivery period may be imposed per day of delay. The Procuring Entity (PE ) may rescind the contract once the cumulative amount of liquidated damages reaches ten percent (10%) of the amount of the contract, without prejudice to other courses of action and remedies open to it.
15. Further information may be obtained from the Procurement Section with telephone number **(074) 661-0430 local 25025** or email address [bacsec.car@dswd.gov.ph](mailto:bacsec.car@dswd.gov.ph)

Republic of the Philippines  
DEPARTMENT OF SOCIAL WELFARE AND DEVELOPMENT  
Cordillera Administrative Region  
40 North Drive, Baguio City

**REQUEST FOR QUOTATION (RFQ)**

LOT NO.	DETAILED DESCRIPTION	QTY	UNIT	UNIT PRICE	TOTAL
1	<b>PURCHASE AND DELIVERY OF OTHER SUPPLIES AND SE: MACHINERY AND EQUIPMENT FOR DRMD</b>				
	<b>Pallet Stretch Film Wrap</b> 500mm x 300mm <i>(Please see attached detailed specification for reference)</i>	20	roll		
	<b>Hand Pallet Jack</b> Hydraulic, atleast 2,500kgs/2.5 tons weight capacity Polyurethane Wheels <i>(Please see attached photo for reference)</i>	2	unit		
	<b>Heavy Duty Hand TruckTrolley</b> 600lbs weight capacity, 2 wheels	5	unit		
<b>TOTAL</b>					
<b>OTHER REQUIREMENTS</b>			<b>COMPLIANCE</b> <small>(please check ( ✓ ) whether can comply or not, no check mark will mean non-compliance)</small>		<b>REMARKS</b>
			<b>Can Comply</b>	<b>Cannot Comply</b>	
he delivery of the goods/services is within is within 10 working days upon receipt of Purchase Order. When the last day of delivery falls on a weekend/holiday, the deadline shall be on the next working day			[ ]	[ ]	
Delivery Place: DSWD-CAR, 40 North Drive, Baguio City			[ ]	[ ]	

• Award shall be made per:

Lot basis

Total Quoted Price

Note: **NO GIFT ALLOWED.** Pursuant to RA 6713, otherwise known as the Code of Conduct and Ethical Standards for Public Officials and Employees. The DSWD reserves the right to reject any or all offers at no costs, waive any therein and accept the offer most advantageous to the government.

Sir:

After having carefully read and accepted your terms and conditions, I / We submit our bid on the item/s quoted above.

**Signature of supplier/representative over printed name:**

**Name of Firm/Dealer/Contractor:**

(This will be the name of the CHEQUE to be Issued)

**Address:**

**Email Address:**

**Contact Number/s:**

**PhilGEPS Registration**

**Number:**

Name and Signature of Convasser



## HAND JACK PALLET PARTS AND MEASUREMENTS

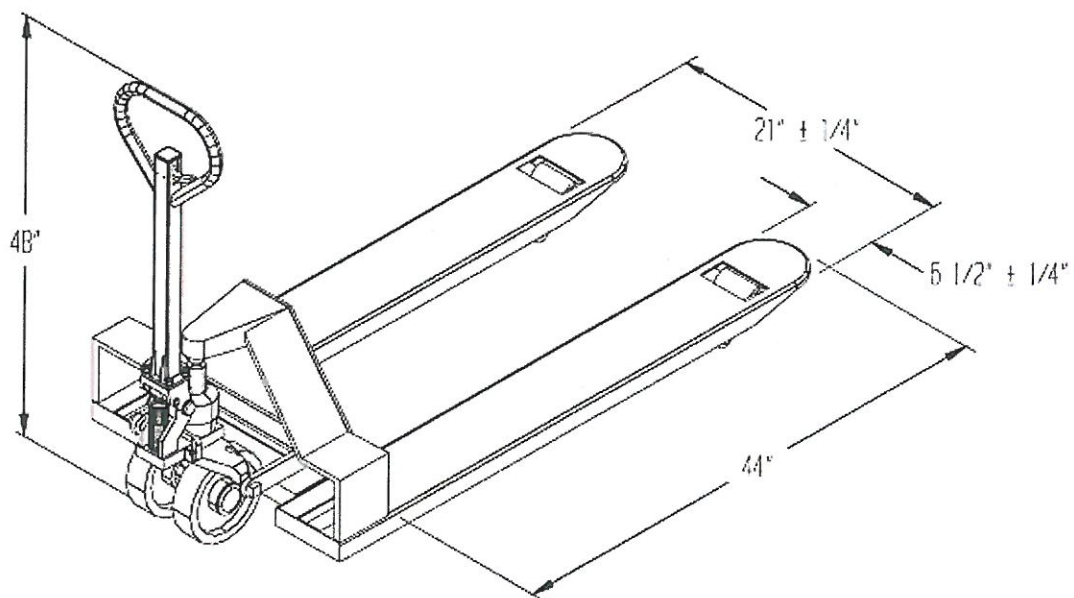
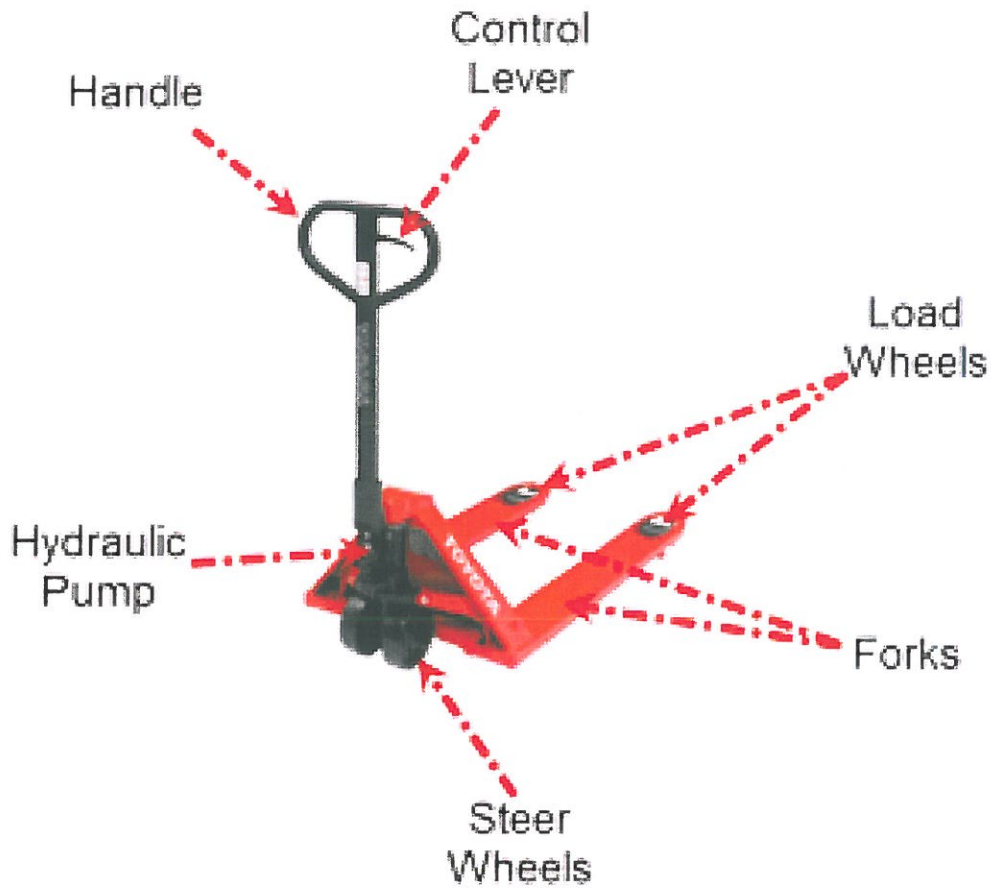

**PALLET STRETCH FILM**

**Stretch Film**

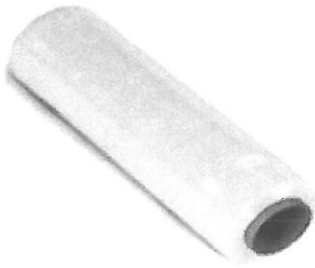

<b>Type</b>	Stretch Film, Plastic Wrapper for Pallet
<b>Unit of Measurement</b>	Roll
<b>Weight</b>	Not less than two (2) kilos (Including paper core)
<b>Width</b>	500 mm (-/+ 2% variance)
<b>Thickness</b>	15 microns (-/+ 2% clearance)
<b>Core Inside Diameter</b>	76 mm (-/+ 2% variance)