

REQUEST FOR QUOTATION (RFQ)

PR/PP No.: 2021-07-434

End-user: AD-BGMS

Name of Project:

RFQ No.: 2021-08-793

Date: AUG 15 2021

ABC: ₱248,705.85

REMOVAL AND REPLACEMENT OF EXISTING STAIRS LAYOUT

SMALL VALUE PROCUREMENT

Sir/Madam:

Please quote your lowest price on the item/s described below inclusive of taxes duly signed by you or your authorized representative, subject to the Terms and Condition provided in this RFQ and submit personally to the Office of the Procurement Section, 40 North Drive, Baguio City or through email at bacsec.car@dswd.gov.ph on or before AUG 20 2021 **12:00PM**.

ENRIQUE H. GASCON JR.
OIC-ARDA/BAC Chairperson *HB*

TERMS AND CONDITIONS:

1. Quotations in excess of the ABC will be **REJECTED**.
2. For total quoted price, quotations with a **dash or zero shall be deemed free of charge**.
3. All entries must be typewritten/printed/longhand. **Any erasure in the quotation must be countersigned by the bidder/representative**, otherwise quotation will be rejected.
4. The Procuring Entity **may give due preference to goods being offered with green component**.
5. If necessary, the BAC through the TWG, may require an ocular inspection of the venue/place of business/goods being offered.
6. Delivery of Goods / Services is **as indicated** in the next page.
7. Price validity shall be for a period of **120 calendar days from RFQ Opening of the BAC until confirmation of Purchase Order by the winning supplier**.
8. The following documents shall be attached upon submission of quotation, otherwise your quotation will not be accepted, please disregard if already submitted:
 - a. **Updated Mayor's / Business Permit**
 - b. **PhilGEPS Registration Certificate or PhilGEPS Registration Number to be indicated in space below (except for Negotiated Procurement - Emergency Cases, Sec. 53.2, RA 9184 IRR)**
 - c. **Income/Business Tax Return (for Small Value Procurement, Direct Contracting above P500K, Emergency Cases above P500K, and Lease of Real Property/Venue).**
9. Where there is discrepancy between: (a) total price per item and unit price for the item as extended or multiplied by the quantity of that item, the unit price shall prevail; (b) stated total price and the actual sum of prices of component items, the lower shall prevail; (c) unit cost in the detailed estimate and unit cost in the bill of quantities, the latter shall prevail.
10. Suppliers/Contractors who **refuse to accept correction of price offer after Bid Evaluation shall be disqualified**.
11. Award of Contract shall be made to the Lowest Calculated Responsive Quotation (LCRQ) that complies to the **technical specifications and the terms and conditions** stated herein.
12. The BAC shall require the bidder with Lowest Calculated Responsive Quotation (LCRQ) to submit the **Omnibus Sworn Statement** prior to issuance of Award / Purchase Order with ABC amounting to **P500,000.00 for Emergency Cases and P50,000.00 above for Small Value Procurement**.
13. If the Supplier fails to deliver the required goods /services as specified in the Award / Purchase Order, the Procuring Entity may **disqualify bidder from participating future procurement activities to be conducted by DSWD-CAR**.
14. **Liquidated damages equivalent to one tenth of one percent (0.001)** of the value of the goods not delivered within the prescribed delivery period may be imposed per day of delay. The Procuring Entity (PE) may rescind the contract once the cumulative amount of liquidated damages reaches ten percent (10%) of the amount of the contract, without prejudice to other courses of action and remedies open to it.
15. Further information may be obtained from the Procurement Section with telephone number **(074) 661-0430 local 25025** or email address bacsec.car@dswd.gov.ph.

Republic of the Philippines
DEPARTMENT OF SOCIAL WELFARE AND DEVELOPMENT
Cordillera Administrative Region
40 North Drive, Baguio City

REQUEST FOR QUOTATION (RFQ)

LOT NO.	DETAILED DESCRIPTION	QUANTITY	UNIT	TOTAL
1	REMOVAL AND REPLACEMENT OF EXISTING STAIRS LAYOUT			
	GENERAL REQUIREMENTS	1	Lot	
	Mobilization/ Demobilization			
	REMOVAL AND REPLACEMENT	1	Lot	
	Removal			
	Replacement			
	<i>See the attached plan for specific details</i>			
	OTHER REQUIREMENTS	COMPLIANCE <small>Place a check (✓) mark whether can comply or not, no check mark will mean non-compliance</small>		REMARKS
		Can Comply	Cannot Comply	
	Contractor's Qualification(s)			
	a. Contractor shall be competent and experienced in the field of Construction with a minimum of one (1) year prior experience.	[]	[]	
	Contractor's Working Hours			
	a. All normal work for this contract shall be performed during normal daylight hours. Any exceptions will require the written approval of the assigned Project Management Officer.	[]	[]	
	Contractor's Responsibilities			
	a. Contractor shall submit own construction schedule within five (5) working days after the receipt of Purchase Order;	[]	[]	
	b. Contractor / Service provider shall assign project engineer / project architect from the start until completion stage;	[]	[]	
	c. Contractor / Service provider shall coordinate to the BGMS all the execution of works;	[]	[]	
	d. Contractor / Service provider shall provide warning signages, project signboard, project log book;	[]	[]	
	e. Contractor / Service provider shall submit statement of works accomplished and progress photos as requirement of the billing request;	[]	[]	
	Other Requirements			
	a. All dimensions / level etc. indicated in the drawing plans are to be verified on the site;	[]	[]	
	b. All materials is subjected for the approval of the end user / BGMS Project Engineer	[]	[]	
	c. Any discrepancies, either between written dimensions and site dimensions shall be brought to the BGMS office before executing the works	[]	[]	
	d. Project Duration: 7 calendar days	[]	[]	
TOTAL PRICE				

• Award shall be made per:

Lot basis

Total Quoted Price

Note: NO GIFT ALLOWED. Pursuant to RA 6713, otherwise known as the Code of Conduct and Ethical Standards for Public Officials and Employees. The DSWD reserves the right to reject any or all offers at no costs, waive any therein and accept the offer most advantageous to the government.

Sir:

After having carefully read and accepted your terms and conditions, I / We submit our bid on the item/s quoted above.

Signature of supplier/representative over printed name: _____

Name of Firm/Dealer/Contractor: _____

(This will be the name of the CHEQUE to be issued)

Name and Signature of Convasser

Address:

Email Address:

Contact Number/s:

PhilGEPS Registration Number:

REPUBLIC OF THE PHILIPPINES
CORDILLERA ADMINISTRATIVE REGION

Contract Reference Number: _____

Name of Project: _____

Removal and Replacement of Existing Stairs Layout

Location of the Project: _____

DSWD FO CAR, # 40 North Drive Baguio City

Standard Form Number SF-INFR-55

Revised On: August 11, 2004

BILL OF QUANTITIES

Columns 1, 2, 3 & 4 are to be filled up by the Procurement Entity				Columns 5 & 6 are to be filled by the bidders	
ITEM NO. 1	ITEM DESCRIPTION 2	UNIT 3	QTY. 4	UNIT PRICE (PESOS) 5	AMOUNT (PESOS) 6
I	GENERAL REQUIREMENTS	Lot	1.00		
II	Removal and Replacement	Lot	1.00		
TOTAL BID PRICE:					
TOTAL AMOUNT IN WORDS:					



AD 16344-001 | REV 00

PROJECT NAME:

PROPOSED STAIRS AT FOCAR

LOCATION:

#40 NORTH DRIVE, BAGUIO
CITY

SHEET CONTENT:

AS SHOWN

APPROVED BY

ARNEL L. GARCIA, CSO II
Regional Director

CONFORMED BY

ENRIQUE M. GASCON JR.
QC-Assistant responsible Director for Administrative

CHECKED BY

JESSE F. CHELIM
QC Chief, Administrative Division

PREPARED BY

JIMMY C. LAYUN, Jr.
PRO. R. ADRIANS

PROJECT/TA No: A.D-IGMS-2021-001

DATE SUBMITTED:

DRAWING STATUS

DATE DESCRIPTION/REMARKS BY

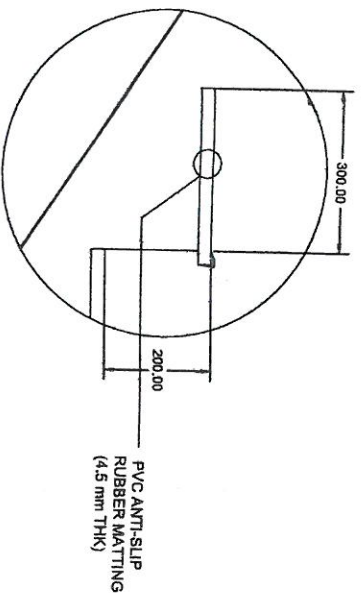

3 DETAIL 1

SCALE 1:1000

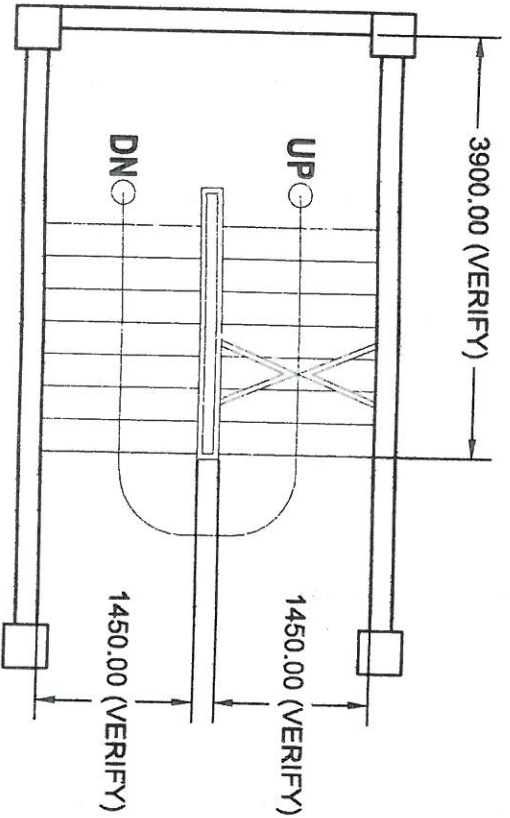

1 STAIR PLAN

SCALE 1:200

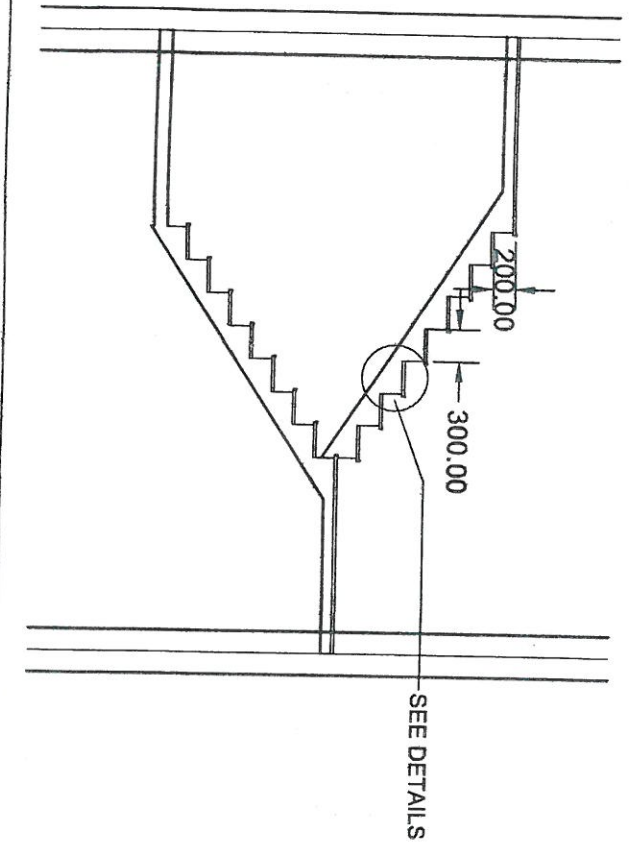

2 STAIR ELEVATION

SCALE 1:200

4 DETAIL 2

SCALE 1:100

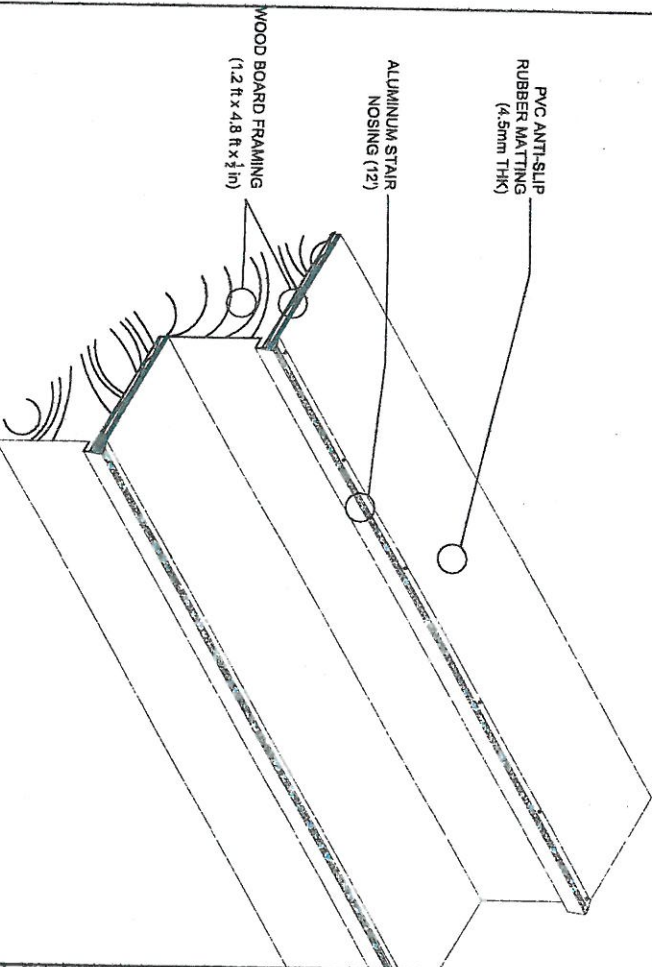

4 DETAIL 2

SCALE 1:100