

REQUEST FOR QUOTATION (RFQ)

PR/PP No.: 2020-11-624

RFQ No.: 2020-11-881

End-user: BGMS

Date: NOV 16 2020

Name of Project:

ABC: ₱130,000.00

**IMPROVEMENT OF CANAL & INSTALLATION OF EXHAUST FANS AT ORD AND
SLP RPMO**

SMALL VALUE PROCUREMENT

Sir/Madam:

Please quote your lowest price on the item/s described below inclusive of taxes duly signed by you or your authorized representative, subject to the Terms and Condition provided in this RFQ and submit personally to the Office of the Procurement Section, 40 North Drive, Baguio City or through email at bacsec.car@dswd.gov.ph on or before NOV 19 2020 6:00PM.

ENRIQUE H. GASCON JR. *EB*
OIC-ARDA/BAC Chairperson

TERMS AND CONDITIONS:

1. Quotations in excess of the ABC will be **REJECTED**.
2. For total quoted price, quotations with a **dash or zero shall be deemed free of charge**.
3. All entries must be typewritten/printed/longhand. **Any erasure in the quotation must be countersigned by the bidder/representative**, otherwise quotation will be rejected.
4. The Procuring Entity **may give due preference to goods being offered with green component**.
5. If necessary, the BAC through the TWG, may require an ocular inspection of the venue/place of business/goods being offered.
6. Delivery of Goods / Services is **as indicated** in the next page.
7. Price validity shall be for a period of **120 calendar days from RFQ Opening of the BAC until confirmation of Purchase Order by the winning supplier**.
8. The following documents shall be attached upon submission of quotation, otherwise your quotation will not be accepted, please disregard if already submitted:
 - o **PhilGEPS Platinum Membership (if not available, attached items a and b);**
 - a. **Updated Mayor's / Business Permit**
 - b. **PhilGEPS Registration Certificate or PhilGEPS Registration Number to be indicated in space below (except for Negotiated Procurement - Emergency Cases, Sec. 53.2, RA 9184 IRR)**
 - o **Income/Business Tax Return (for Small Value Procurement, Direct Contracting above P500K, Emergency Cases above P500K, and Lease of Real Property/Venue).**
9. Where there is discrepancy between: (a) total price per item and unit price for the item as extended or multiplied by the quantity of that item, the unit price shall prevail; (b) stated total price and the actual sum of prices of component items, the latter shall prevail; (c) unit cost in the detailed estimate and unit cost in the bill of quantities, the latter shall prevail.
10. Suppliers/Contractors who **refuse to accept correction of price offer after Bid Evaluation shall be disqualified**.
11. Award of Contract shall be made to the Lowest Calculated Responsive Quotation (LCRQ) that complies to the **technical specifications** and the **terms and conditions** stated herein.
12. The BAC shall require the bidder with Lowest Calculated Responsive Quotation (LCRQ) to submit the following document prior to issuance of Award / Purchase Order with ABC amounting to P50,000.00 and above.
 - o **Omnibus Sworn Statement (only for Negotiated Procurement - Emergency Cases, Sec. 53.2 and Small Value Procurement Sec. 53.9)**
13. If the Supplier fails to deliver the required goods /services as specified in the Award / Purchase Order, the Procuring Entity may **disqualify bidder from participating future procurement activities to be conducted by DSWD-CAR**.
14. **Liquidated damages equivalent to one tenth of one percent (0.001)** of the value of the goods not delivered within the prescribed delivery period may be imposed per day of delay. The Procuring Entity (PE) may rescind the contract once the cumulative amount of liquidated damages reaches ten percent (10%) of the amount of the contract, without prejudice to other courses of action and remedies open to it.
15. Further information may be obtained from the Procurement Section with telephone number **(074) 661-0430 local 25025** or email address **bacsec.car@dswd.gov.ph**.

REQUEST FOR QUOTATION (RFQ)

| ITEM NO. | DETAILED DESCRIPTION | QUANTITY | UNIT | TOTAL |
|----------|--|---|---------------|----------------|
| | IMPROVEMENT OF CANAL & INSTALLATION OF EXHAUST FANS AT ORD AND SLP RPMO | | | |
| 1 | General Requirements Structure Excavation Formworks Reinforcing Steel Works Concreting works Steel Gratings Supply & Installation of 6pcs-12" exhaust fans Construction Safety & Health | 1 | lot | |
| | Please see attached bill of quantities for your quotation | | | |
| | OTHER REQUIREMENTS | COMPLIANCE Place a check (✓) mark whether can comply or not, no check mark will mean non-compliance | | REMARKS |
| | | Can Comply | Cannot Comply | |
| | Completion must be within 23 calendar days from date of receipt of Purchase Order. | [] | [] | |
| | Attach additional detailed estimate | [] | [] | |
| | The place of delivery of the goods / services is AT DSWD-CAR, #40 NORTH DRIVE, BAGUIO CITY. | [] | [] | |

• Award shall be made per:

Item Basis

Total Quoted Price

Note: NO GIFT ALLOWED. Pursuant to RA 6713, otherwise known as the Code of Conduct and Ethical Standards for Public Officials and Employees. The DSWD reserves the right to reject any or all offers at no costs, waive any therein and accept the offer most advantageous to the government.

Sir:

After having carefully read and accepted your terms and conditions, I / We submit our bid on the item/s quoted above.

*Signature of
supplier/representative over printed*

Name of Firm/Dealer/Contractor:

(This will be the name of the CHEQUE to be issued)

Address:

Email Address:

Contact Number/s:

PhilGEPS Registration Number:

Name and Signature of Canvasser

YUB/bey/beki

REPUBLIC OF THE PHILIPPINES
CORDILLERA ADMINISTRATIVE REGION

Contract Reference Number: _____

Name of Project: IMPROVEMENT OF CANAL & INSTALLATION
OF EXHAUST FANS AT ORD & SLP RPMO

Location of the Project: # 40 NORTH DRIVE, BAGUIO CITY

Standard Form Number SF-INFR-55

Revised on: August 11, 2004

BILL OF QUANTITIES

| Columns 1, 2, 3, & 4 are to be filled up by the Procuring Entity | | | | Columns 5 & 6 are to be filled by the bidders | |
|---|--|-----------|-----------|--|---------------------|
| ITEM NO. | ITEM DESCRIPTION 2 | UNIT 3 | QTY. 4 | UNIT PRICE (PESOS) 5 | AMOUNT (PESOS) 6 |
| A | GENERAL REQUIREMENTS | lot | 1.00 | | |
| 103 | STRUCTURE EXCAVATION | cu.m. | 2.20 | | |
| B | FORMWORKS | sq. m. | 6.00 | | |
| 404 | REINFORCING STEEL WORKS | kgs. | 167.28 | | |
| 405 | CONCRETING WORKS | cu.m. | 1.50 | | |
| 503 | STEEL GRATINGS | lot | 1.00 | | |
| D | SUPPLY & INSTALLATION OF 6PCS-12" EXHAUST FANS (Includes electrical & ducting connections) | lot | 1.00 | | |
| E | CONSTRUCTION SAFETY & HEALTH | lot | 1.00 | | |
| TOTAL BID PRICE: | | | | | |
| TOTAL AMT. IN WORDS: (in words) | | | | | |
| | | | | | |

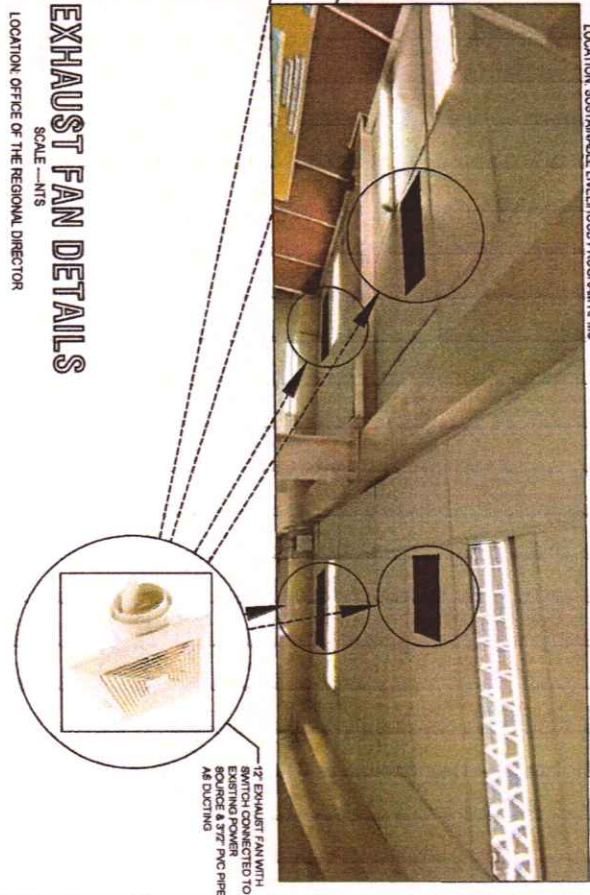
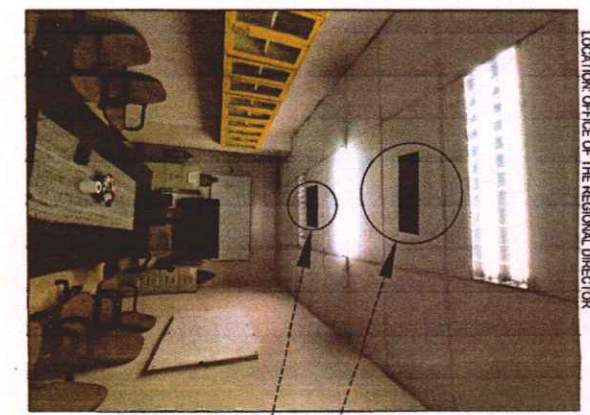
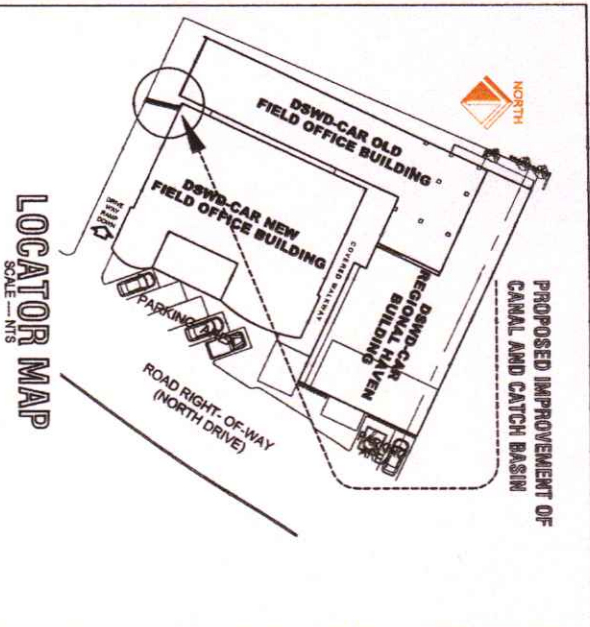

EXHAUST FAN DETAILS
SCALE - NTS
LOCATION: OFFICE OF THE REGIONAL DIRECTOR

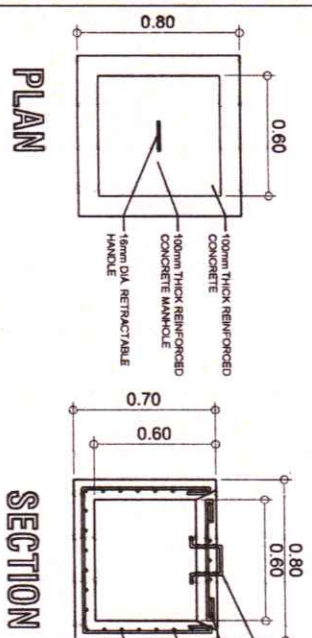

CATCH BASIN DETAILS
SCALE - 1:1000

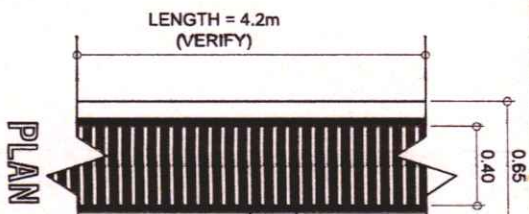

CANAL DETAILS
SCALE - 1:1000

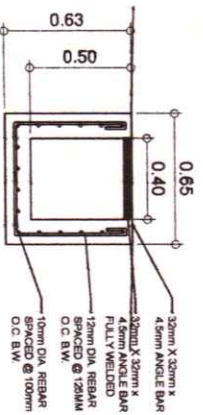

SECTION

| | | | | | | | |
|---|--|---|--|--|--|---|-------------------------------|
| <p>REPUBLIC OF THE PHILIPPINES DEPARTMENT OF SOCIAL WELFARE AND DEVELOPMENT CORDILLERA ADMINISTRATIVE REGION #40 North Drive, Baguio City TEL. No. 442-7817</p> | <p>PROJECT TITLE: IMPROVEMENT OF CANAL & INSTALLATION OF EXHAUST FANS AT ORD & SLP RPMD</p> | <p>PREPARED BY: BERNARD L. ANAOYON AOI - BGMS</p> | <p>REVIEWED BY: RINA CLARE L. REYES OIC - CHIEF, ADMINISTRATIVE DIVISION</p> | <p>RECOMMENDING APPROVAL: ENRIQUE G. GASCON JR. RPA DSWD-CAR</p> | <p>APPROVED: LEO L. QUINTILLA OIC - REGIONAL DIRECTOR DSWD-CAR</p> | <p>SHEET CONTENT: LOCATOR MAP EXHAUST FAN DETAILS CATCH BASIN DETAILS CANAL DETAILS</p> | <p>SHEET NO. A 01</p> |
| | <p>PROJECT LOCATION: #40 North Drive, Baguio City</p> | <p>SCALE: 1:1000</p> | <p>SCALE: NTS</p> | <p>SCALE: 1:1000</p> | <p>SCALE: 1:1000</p> | <p>SCALE: 1:1000</p> | <p>SCALE: 1:1000</p> |