

REQUEST FOR QUOTATION (RFQ)

PR/PP No.: 2022-12-734
End-user: BGMS/RHWG
Name of Project:

RFQ No.: 2022-12-936
Date: DEC 14 2022
ABC ₱96,290.00

**PURCHASE AND DELIVERY OF ELECTRICAL AND OTHER MATERIALS FOR
RHWG**

Mode of Procurement: SMALL VALUE PROCUREMENT

Sir/Madam:

Please quote your lowest price on the item/s described below inclusive of taxes duly signed by you or your authorized representative, subject to the Terms and Condition provided in this RFQ and submit personally to the Office of the Procurement Section, 40 North Drive, Baguio City or through email at bacsec.car@dswd.gov.ph on or before **DEC 19 2022 12:00NN.**

ENRIQUE H. GASCON JR.
BAC Chairperson 

TERMS AND CONDITIONS:

1. Quotations in excess of the ABC will be **REJECTED**.
2. For unit price/s, quotations with a **dash or zero shall be deemed free of charge**.
3. All entries must be typewritten/printed/longhand. **Any erasure in the quotation must be countersigned by the bidder/representative**, otherwise quotation will be rejected.
4. The Procuring Entity **may give due preference to goods being offered with green component**.
5. If necessary, the BAC through the TWG, may require an ocular inspection of the venue/place of business/goods being offered.
6. Delivery of Goods / Services is **as indicated** in the next page.
7. Price validity shall be for a period of **120 calendar days from RFQ Opening of the BAC until confirmation of Purchase Order by the winning supplier**.
8. The following documents shall be attached upon submission of quotation, otherwise your quotation will not be accepted, please disregard if already submitted:
 - a. **Updated Mayor's / Business Permit**
 - b. **PhilGEPS Registration Certificate or PhilGEPS Registration Number to be indicated in space below (except for Negotiated Procurement - Emergency Cases, Sec. 53.2, RA 9184 IRR)**
 - c. **Income/Business Tax Return (for Small Value Procurement, Direct Contracting above P500K, Emergency Cases above P500K, and Lease of Real Property/Venue)**
 - d. **Official Receipt issued by BIR (a mere picture of the receipt can suffice)**
9. Where there is discrepancy between: (a) total price per item and unit price for the item as extended or multiplied by the quantity of that item, the unit price shall prevail; (b) stated total price and the actual sum of prices of component items, the lower shall prevail; (c) unit cost in the detailed estimate and unit cost in the bill of quantities, the lower shall prevail.
10. Suppliers/Contractors who **refuse to accept correction of price offer after Bid Evaluation may be disqualified**.
11. Award of Contract shall be made to the Lowest Calculated Responsive Quotation (LCRQ) that complies to the **technical specifications** and the **terms and conditions** stated herein.
12. The BAC shall require the bidder with Lowest Calculated Responsive Quotation (LCRQ) to submit the **Omnibus Sworn Statement** prior to issuance of Award / Purchase Order with ABC amounting to **P500,000.00** for **Emergency Cases** and **P50,000.00** above for **Small Value Procurement**.
13. If the Supplier fails to deliver the required goods /services as specified in the Award / Purchase Order, the Procuring Entity may **disqualify bidder from participating future procurement activities to be conducted by DSWD-CAR**.
14. **Liquidated damages equivalent to one tenth of one percent (0.001)** of the value of the goods not delivered within the prescribed delivery period may be imposed per day of delay. The Procuring Entity (PE) may rescind the contract once the cumulative amount of liquidated damages reaches ten percent (10%) of the amount of the contract, without prejudice to other courses of action and remedies open to it.
15. Further information may be obtained from the Procurement Section with telephone number **(074) 661-0430 local 25025** or email address **bacsec.car@dswd.gov.ph**.

Republic of the Philippines
DEPARTMENT OF SOCIAL WELFARE AND DEVELOPMENT
Cordillera Administrative Region
40 North Drive, Baguio City

REQUEST FOR QUOTATION (RFQ)

| LOT NO. | DETAILED DESCRIPTION | QTY | UNIT | UNIT PRICE | TOTAL |
|--|---|-----|-------------------|---------------|----------------|
| 1 | PURCHASE AND DELIVERY OF ELECTRICAL AND OTHER MATERIALS FOR RHWG | | | | |
| | MDF Board - 4' x 8' x 3/4" | 3 | pcs | | |
| | Stainless Steel Grab Bars - dia.: 50 mm - length: 50 cm | 4 | pcs | | |
| | Wall Fan - 16" dia - plastic blade - 65W - 3 speed | 1 | pc | | |
| | Wood Moulding - 1/2" x 1" x 12' | 6 | pcs | | |
| | PVC Moulding - 1/2" x 3/4" x 8' | 10 | pcs | | |
| | 6W Round Surface Mounted LED Light - Day light | 20 | pcs | | |
| | 18W Square Recessed LED Light - Day light | 50 | pcs | | |
| | #12 THHN Wire | 1 | box | | |
| | 1-gang Switch | 5 | pcs | | |
| | 2-gang Switch | 5 | pcs | | |
| | 2-gang GFCI Socket | 5 | pcs | | |
| TOTAL | | | | | |
| OTHER REQUIREMENTS | | | COMPLIANCE | | REMARKS |
| | | | Can Comply | Cannot Comply | |
| Delivery of Goods is within 15 calendar days after receipt of Purchase Order. Delivery place at DSWD FO CAR, #40 NORTH Drive, Baguio City. If the last day of delivery falls on Saturday/Sunday/holiday, the delivery of goods can be moved to the next working day. | | | [] | [] | |
| Service Provider must have Active Landbank Account for Payment Purposes. For other banks, service charge will be deducted upon payment on the account. | | | [] | [] | |
| PAYMENT SHALL BE MADE THRU LANDBANK OF THE PHILIPPINES | | | | | |

• Award shall be made per: x Lot basis Total Quoted Price

Note: NO GIFT ALLOWED. Pursuant to RA 6713, otherwise known as the Code of Conduct and Ethical Standards for Public Officials and Employees. The DSWD reserves the right to reject any or all offers at no costs, waive any therein and accept the offer most advantageous to the government.

Sir: After having carefully read and accepted your terms and conditions, I / We submit our bid on the item/s quoted above.

Signature of supplier/representative over printed name: _____

Name of Firm/Dealer/Contractor: _____

Address: _____

Email Address: _____

Contact Number/s: _____



PhilGEPS Registration Number: _____

Name and Signature of Canvasser

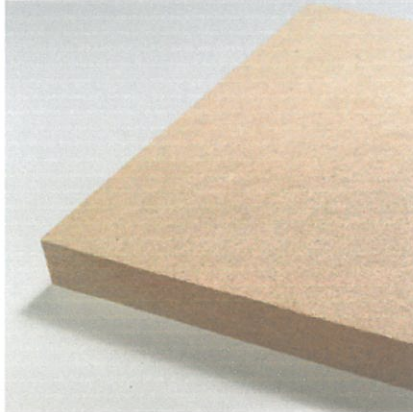

TECHNICAL SPECIFICATION

| | |
|-----------------------|--------------------------|
| Date Submitted | November 28, 2022 |
| TA Control No. | |

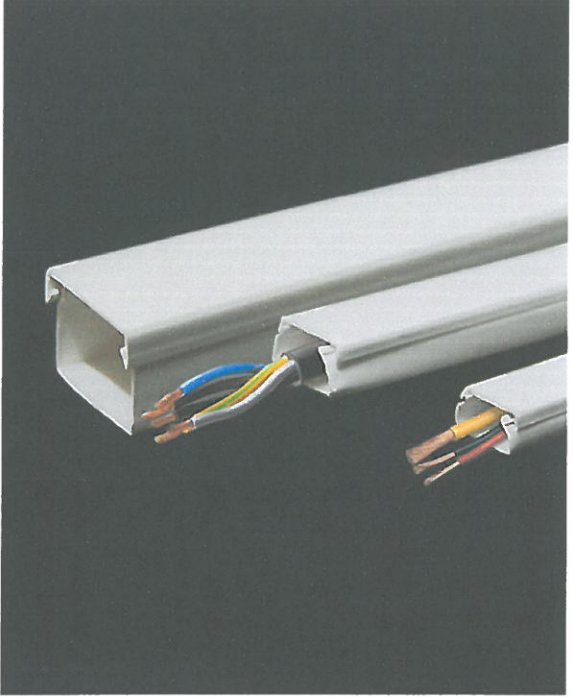

| |
|---|
| Requesting OBSU : RHWG |
| TA Subject/Title : Purchase and Delivery of Electrical and other materials for RHWG. |

| Item | Description and Specification | Actual/Sample Picture <i>(if applicable)</i> |
|------|--|---|
| 1 | MDF Board - 4' x 8' x 3/4" |  |
| 2 | Stainless Steel Grab Bars - dia.: 50 mm - length: 50 cm |  |
| 3 | Wall Fan - 16" dia - plastic blade - 65W - 3 speed |  |



| | | |
|---|--|--|
| 4 | Wood Moulding -1/2" x 1" x 12' |  |
| 5 | PVC Moulding -1/2" x 3/4" x 8' |  |
| 6 | 6W Round Surface Mounted LED Light - Day light |  |

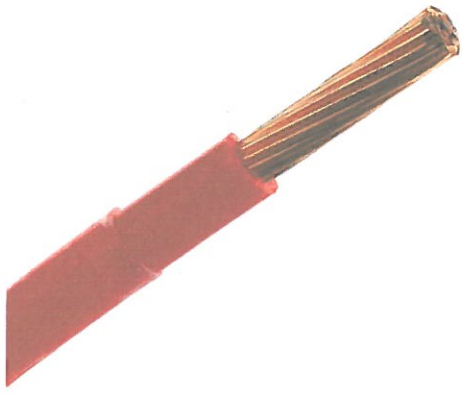
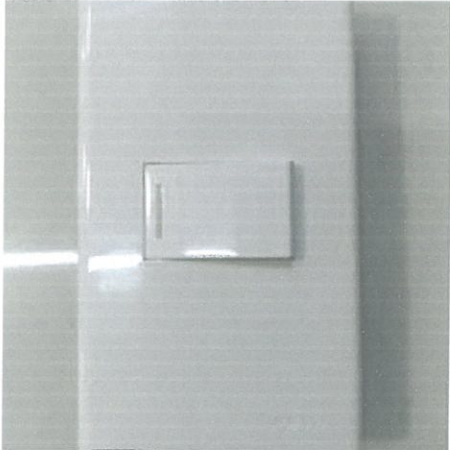

| | | |
|----|--|--|
| 7 | 18W Square Recessed LED Light - Day light |  |
| 8 | #12 THHN Wire |  |
| 9 | 1-gang Switch |  |
| 10 | 2-gang Switch |  |



| | | |
|----|--------------------|--|
| 11 | 2-gang GFCI Socket |  |
|----|--------------------|--|

Prepared by:

COLLIN JONES C. TUNGOL
Project Development Officer II, BGMS