

REQUEST FOR QUOTATION (RFQ)

PR/PP No.: 2022-06-402
End-user: DRMD
Name of Project: _____

RFQ No.: 2022-07-505
Date: JUL 14 2022
ABC: ₱122,600.00

**PURCHASE AND DELIVERY OF OTHER SUPPLIES AND SE: MACHINERY
AND EQUIPMENT FOR DRMD**

Mode of Procurement: SMALL VALUE PROCUREMENT

Sir/Madam: _____

Please quote your lowest price on the item/s described below inclusive of taxes duly signed by you or your authorized representative, subject to the Terms and Condition provided in this RFQ and submit personally to the Office of the Procurement Section, 40 North Drive, Baguio City or through email at bacsec.car@dswd.gov.ph on or before JUL 20 2022 12:00NN.

ENRIQUE H. GASCON JR.
BAC Chairperson

TERMS AND CONDITIONS:

1. Quotations in excess of the ABC will be **REJECTED**.
2. For unit price/s, quotations with a **dash or zero shall be deemed free of charge**.
3. All entries must be typewritten/printed/longhand. **Any erasure in the quotation must be countersigned by the bidder/representative**, otherwise quotation will be rejected.
4. The Procuring Entity **may give due preference to goods being offered with green component**.
5. If necessary, the BAC through the TWG, may require an ocular inspection of the venue/place of business/goods being offered.
6. Delivery of Goods / Services is **as indicated** in the next page.
7. Price validity shall be for a period of **120 calendar days from RFQ Opening of the BAC until confirmation of Purchase Order by the winning supplier**.
8. The following documents shall be attached upon submission of quotation, otherwise your quotation will not be accepted, please disregard if already submitted:
 - a. **Updated Mayor's / Business Permit**
 - b. **PhilGEPS Registration Certificate or PhilGEPS Registration Number to be indicated in space below (except for Negotiated Procurement - Emergency Cases, Sec. 53.2, RA 9184 IRR)**
 - c. **Income/Business Tax Return (for Small Value Procurement, Direct Contracting above P500K, Emergency Cases above P500K, and Lease of Real Property/Venue)**
 - d. **Official Receipt issued by BIR(a mere picture of the receipt can suffice)**
9. Where there is discrepancy between: (a) total price per item and unit price for the item as extended or multiplied by the quantity of that item, the unit price shall prevail; (b) stated total price and the actual sum of prices of component items, the lower shall prevail; (c) unit cost in the detailed estimate and unit cost in the bill of quantities, the lower shall prevail.
10. Suppliers/Contractors who **refuse to accept correction of price offer after Bid Evaluation may be disqualified**.
11. Award of Contract shall be made to the Lowest Calculated Responsive Quotation (LCRQ) that complies to the **technical specifications** and the **terms and conditions** stated herein.
12. The BAC shall require the bidder with Lowest Calculated Responsive Quotation (LCRQ) to submit the Omnibus Sworn Statement prior to issuance of Award / Purchase Order with ABC amounting to P500,000.00 for Emergency Cases and P50,000.00 above for Small Value Procurement .
13. If the Supplier fails to deliver the required goods /services as specified in the Award / Purchase Order, the Procuring Entity may **disqualify bidder from participating future procurement activities to be conducted by DSWD-CAR**.
14. **Liquidated damages equivalent to one tenth of one percent (0.001)** of the value of the goods not delivered within the prescribed delivery period may be imposed per day of delay. The Procuring Entity (PE) may rescind the contract once the cumulative amount of liquidated damages reaches ten percent (10%) of the amount of the contract, without prejudice to other courses of action and remedies open to it.
15. Further information may be obtained from the Procurement Section with telephone number **(074) 661-0430 local 25025** or email address **bacsec.car@dswd.gov.ph**.

REQUEST FOR QUOTATION (RFQ)

LOT NO.	DETAILED DESCRIPTION	QTY	UNIT	UNIT PRICE	TOTAL
1	PURCHASE AND DELIVERY OF OTHER SUPPLIES AND SE: MACHINERY AND EQUIPMENT FOR DRMD				
	STRETCH FILM, PLASTIC WRAPPER FOR PALLET 500mm x 300mm <i>Please see attached detailed specifications for reference</i>	20	roll		
	HAND PALLET JACK Hydraulic Atleast 2,500 kgs tons weight capacity Polyurethane wheels <i>Please see attached photo detailed specifications for reference</i>	2	unit		
	HEAVY DUTY HAND TRUCK TROLLEY Atleast 300 kgs weight capacity, four-wheel flatform <i>Please see attached photo detailed specifications for reference</i>	5	unit		
	OTHER REQUIREMENTS	COMPLIANCE <small><i>please check (✓) whether can comply or not, no check mark will mean non-compliance</i></small>		REMARKS	
	<i>Delivery period is within 10 calendar days upon receipt of Purchase Order. When the last day of delivery falls on a weekend/holiday, the deadline shall be on the next working day.</i>	Can Comply			
	<i>Delivery place is at DSWD-CAR #40 Northdrive Baguio City</i>				
TOTAL PRICE					

• Award shall be made per:

Lot basis

Total Quoted Price

*Note: **NO GIFT ALLOWED**. Pursuant to RA 6713, otherwise known as the Code of Conduct and Ethical Standards for Public Officials and Employees. The DSWD reserves the right to reject any or all offers at no costs, waive any therein and accept the offer most advantageous to the government.*

Sir:

After having carefully read and accepted your terms and conditions, I / We submit our bid on the item/s quoted above.

*Signature of
supplier/representative over
printed name:*

Name of Firm/Dealer/Contractor:

(This will be the name of the CHEQUE to be issued)

Name and Signature of Canvasser

Address:

Email Address:

Contact Number/s:

PhilGEPS Registration Number:

YUB/dnev

TECHNICAL SPECIFICATIONS AND PHOTOS

1. Pallet Stretch Film

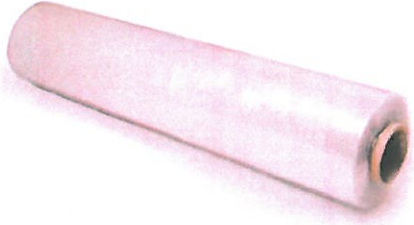
	Type	Stretch Film, Plastic Wrapper for Pallet
	Unit of Measurement	Roll
	Weight	Not less than two (2) kilos (including upper core)
	Thickness	15 microns (-/+ 2% clearance)
	Core Inside Diameter	76 mm (-/+ 2% variance)

2. Hand Pallet Jack, Hydraulic

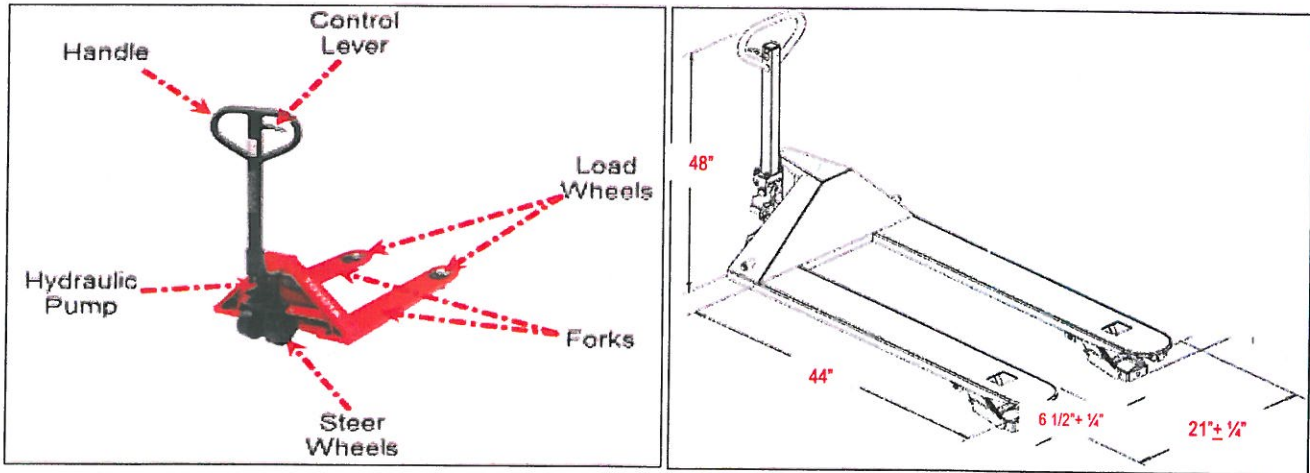

3. Heavy Duty Hand Truck Trolley

